



LONG-LASTING EFFICIENCY

As a critical component of thermal fluid heating systems, tank heating coils play a crucial role in the heating and maintenance of large quantities of material. Because tank maintenance is a time-consuming and challenging task, tank coils must be designed for durability, reliability, and efficiency.

With the use of seamless pipe and solid helically wound fins, our tank coils are built for peak performance. Whether made with carbon steel or 316L stainless steel, our designs are built to last for decades.

CUSTOMIZATION

We'll build tank coils to your exact thermal needs. No waste, no extra expense. Whether your heating medium is steam or thermal fluid, our tank coils provide the solution.

We can build coils to fit into an existing tank manway or specialty tank with vertical or horizontal installation. If you have a need, our team of engineers can work with you to design a coil that meets your requirements – and exceeds your expectations!

316L SS COILS

When you work with Enerquip, you have access to our decades of stainless steel experience. Our bare or helically wound coils can be made with carbon steel or when corrosion is a concern, such as biofuels, 316L stainless steel.

Our coils come in various thicknesses, including schedule 40 or 80, along with sturdy tube supports and legs.



HELICALLY WOUND VS. LONGITUDINAL

While there are many ways a tank coil can be built, experience has proven that tank coils with helically wound fins are best in most scenarios. Longitudinal fins are an alternative option, but they tend to fall short of their helical coil counterparts in several ways.

The benefits of helically wound coils include:

- **Better Heat Transfer:** Horizontally installed helically wound fin tubes have twice the heat transfer of a longitudinal solution.
- **Reduced Cost:** Helically wound coils require half the coils of their longitudinal counterparts - saving you significant capital and installation.
- **Reduced Coking:** A helically wound fin design removes the 'dead spots' that occur in a longitudinal fin. This reduces fluid stagnation and makes helically wound coils less likely to coke.



Twice the heat transfer with helically wound coils.



Used longitudinal coils showing significant coking.

HELICALLY WOUND VS. BARE PIPE

Bare pipe or helically wound coils? That is the question. And the answer is, it depends.

Bare fins are often less of an investment and are better for highly viscous products where fouling may be a concern.

With up to 12x greater surface area, helically wound coils are a highly efficient option. Greater heat transfer means significantly less pipe is needed to heat the tank. This can save you money and installation time.

Let our team of engineers suggest the best option for your application.

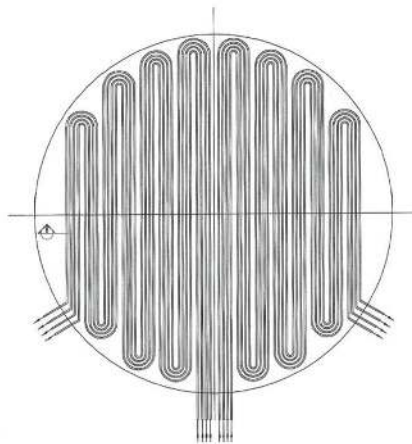

Bare Pipe
Tank Heating Design

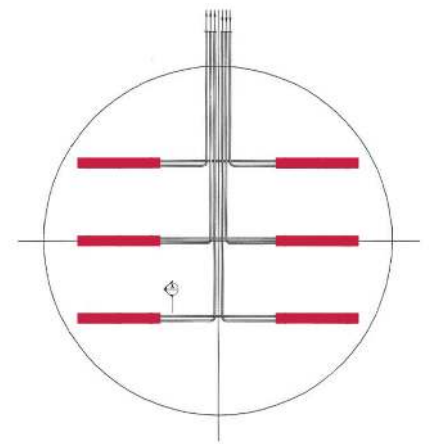

Helically Wound
Tank Heating Design

Want more? Enerquip also designs and builds heat exchangers, industrial heaters, and more. Learn for yourself why Enerquip's quality and service is unmatched in the industry. Call us, today!